



OVERSIZED HP OIL TANKS

Steel oil tanks for HP Series air-hydraulic pumps, oil capacity 2.5L (SL) and 4L (XL)

Series: Accessories

Product line: HP series, air-hydraulic pumps

- Made of painted steel
- Maximum resistance to shocks, rubbing, high temperatures, deformation
- Durability over time
- Side slots for installation on the application (or for inserting parking feet and / or pivoting wheels)
- SL tank with 2.5L capacity (2.15L usable)
- XL tank with 4L capacity (3.5L usable)
- Standard color: black
- Other colors on demand (MOQ required)

Description

The oversized SL and XL tanks of the HP Series are useful accessories to increase the capacity of the HP air-hydraulic pumps and allow the complete extension of large cylinders. 2.5 and 4L capacities for maximum versatility. Entirely made of steel and powder coated in black.

Size:

SL

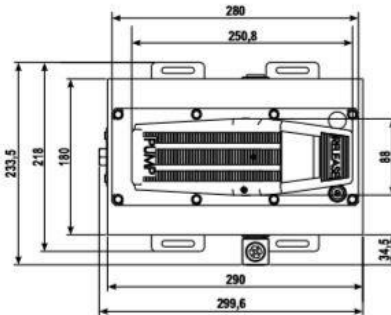
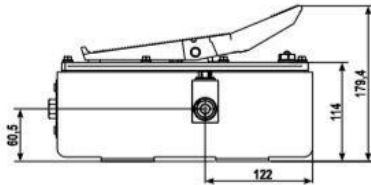

XL

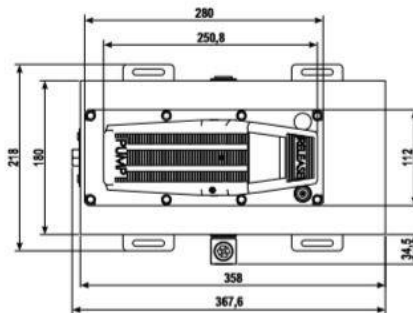
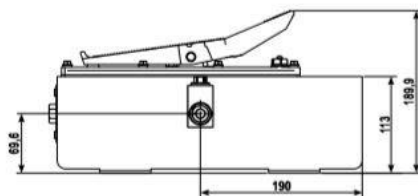

To order:

- 305170090 HP OIL TANK SL 2,5L BLACK
 305170100 HP OIL TANK XL 4L BLACK
 3051700xx KIT HP OIL TANK SL-XL

Including:

- Delivery and relief valve fittings
- Lid / tank gasket
- Air flange